

LOQUET DE COMPRESSION 35 MM



Loquet à compression qui se ferme et se serre d'un mouvement continu d'un demi-tour. Le premier tour de 90° déplace la came de 90°, le second tour de 90° rétracte la came de 6 mm. Le loquet est fourni assemblé et la came est commandée séparément. Degré de protection IP65, également classé comme étanche selon la norme NEMA 4.



MATÉRIAU

Cam: Acier, galvanisé

Housing: Zinc die cast, chrome plated or black coated

Insert: Zinc die cast, chrome plated or black coated

Écrou: Zinc moulé sous pression, zingué

RELATED PRODUCTS

Other materials: 6-135

Handles and knobs: 2-360

Keys: 2-372, 2-370

Needed components for a complete system:

2-411-01, 2-411-02

Use the Index Code at industrilas.com

TESTS & STANDARDS

Other inserts on request.

Latch is supplied with screw with mechanical thread lock.

Handles and knobs for inserts Square 8 / M6 and Triangle 10 / M6 see Index Code 2-360.

Standards: IP65, NEMA 4, DIN EN 61373

Cutout: COMBI

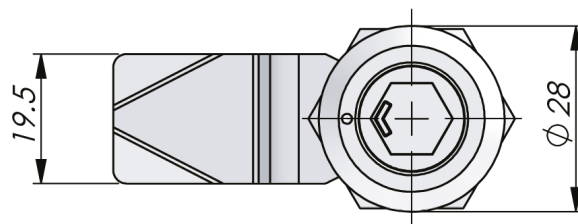
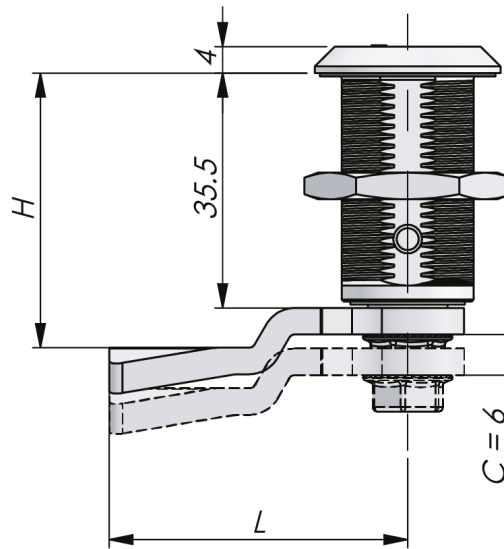

Industrilas
— When access counts —

Make your selections in each column to create your article number (AAAAAA-BB-HHLL)

AAAAAA	Housing	BB	Insert	HHLL	H/L en mm
241387	Chrome	01	Hexagone 11	0000	Sans came
241587	Noir	09	Carré 8 avec flèche	2145	21 / 45
		11	Carré 8 / M6	2345	23 / 45
		12	Triangle 7	2545	25 / 45
		13	Triangle 8	2745	27 / 45
		14	Triangle 10	2945	29 / 45
		16	Double panneton 3	3145	31 / 45
		17	Double panneton 5	3345	33 / 45
		18	DB - Deutsche Bahn. Sur demande.	3545	35 / 45
		20	Fendue	3745	37 / 45
		21	Recessed hexagon 10	3945	39 / 45
		22	Recessed hexagon 8	4145	41 / 45
		28	Triangle 10 / M5	4345	43 / 45
		47	Goupille hexagonale encastrée 8 / 3 mm	4545	45 / 45
		48	Carré encastré 8	4745	47 / 45
		56	Tubulaire Asymétrique	4945	49 / 45
		79	Triangle 6,5	5145	51 / 45
				5345	53 / 45
				5545	55 / 45
				5745	57 / 45
				5945	59 / 45
				6145	61 / 45
				6345	63 / 45
				6545	65 / 45
				6745	67 / 45

* Straight cam.

